

APPLICATIONS INFORMATION

LINEAR HALL-EFFECT SENSORS

by Joe Gilbert and Ray Dewey

LINEAR SENSORS — FEATURES & BENEFITS

Linear sensors are designed to respond to a wide range of positive or negative magnetic fields. Critical to the performance of linear sensors is their sensitivity and linearity over their specified operating temperature range. Allegro's 4th-generation linear sensors, the A3515 and A3516, optimize these design criteria. These ratiometric sensors have a sensitivity of 5 mV/gauss and 2.5 mV/gauss, respectively, an operating temperature range of -40°C to +150°C, and are temperature compensated over their full operating range.

Linear Hall-effect sensors are immune to most environmental disturbances that may affect optical or mechanical devices, such as vibration, moisture, dirt or oil films, ambient lighting, etc.

A Few of the Many Possible Applications

- Current sensing
- Power sensing (watt-hour metering)
- Current trip-point detection
- Strain gauge
- Biased (magnetically) sensing applications
- Ferrous metal detectors
- Proximity sensing
- Joy-stick with intermediate position sensing
- Liquid-level sensing
- Temperature/pressure/vacuum sensing (with bellows assembly)
- Throttle or air valve position sensing
- Non-contact potentiometers

Ratiometric Defined

Most linear Hall-effect sensors are "ratiometric" where the quiescent output voltage (typically 1/2 the supply voltage) and sensitivity are proportional to the supply voltage.

For example: with a supply voltage of 5.0 V and no magnetic field present, the A3515 sensor's quiescent

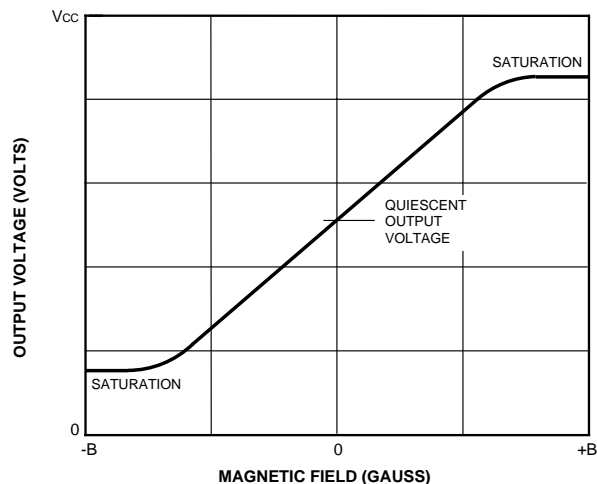

Dwg. PRE-507

Linear Sensor Characteristic

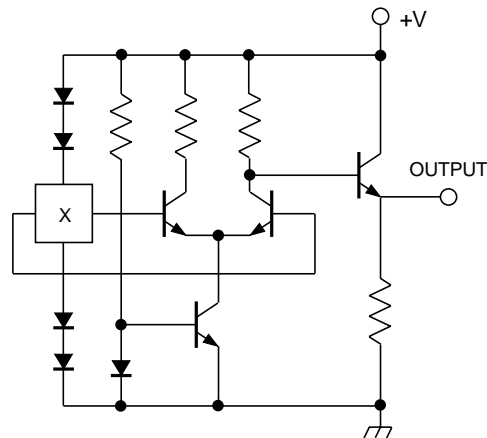

Dwg. FH-021

Early Linear Ratiometric Sensor
Using Single Hall Element

output will typically be 2.5 V, and will change at a rate of 5.0 mV/G. If the supply voltage increases to 5.5 V, the quiescent output voltage will change to 2.75 V, and the sensitivity will increase to 5.5 mV/G.

LINEAR HALL-EFFECT SENSORS

Characteristic	Allegro Type Number						
	UGN3501*	UGN3503	UGN3508	UGN3507	UGN3506*	A3516	A3515
Ratiometric	no	yes	yes	yes	yes	yes	yes
Supply Voltage	8—12 V	4.5—6 V	4.5—6 V	4.5—6 V	4.5—6 V	4.5—8 V	4.5—8 V
Quiescent Output	3.6 V	$V_{CC}/2$	$V_{CC}/2$	$V_{CC}/2$	$V_{CC}/2$	$V_{CC}/2$	$V_{CC}/2$
Sensitivity @ 5 V	0.7 mV/G	1.3 mV/G	2.5 mV/G	2.5 mV/G	2.5 mV/G	2.5 mV/G	5.0 mV/G
Stability	not spec'd	not spec'd	± 50 G	± 35 G	± 20 G	± 10 G	± 10 G

*Discontinued — shown for comparison only.

A3506/07/08 Family of Linear Sensors

The original (1978) UGN3501/03 linear Hall-effect sensors met the basic requirement for contactless sensing but were extremely sensitive to temperature changes and mechanical stress. The A3506/07/08 are 2nd-generation linear sensors utilizing multiple sensors to cancel out these effects on the Hall sensor.

The output of these linear sensors is set to compensate for the negative temperature coefficient of samarium-cobalt magnets (-0.02%/°C).

A3515/16 Family of Linear Sensors

The A3515/16 BiCMOS linear sensors utilize a single Hall sensor that is electronically rotated to cancel out the stress effects on the Hall sensor. These devices use a proprietary dynamic offset cancellation technique, with an internal high-frequency clock to reduce the residual offset voltage of the Hall element, which is normally caused by device overmolding, temperature dependencies, and thermal stress. This technique produces devices that have an extremely stable quiescent Hall output voltage, are immune to thermal stress, and have precise recoverability after temperature cycling.

Linear sensor basic specifications (see data sheets for complete specifications) are shown above.

Calibrated Linear

Allegro offers as an application design aid, a calibrated linear sensor. This utilizes the newest A3515 or A3516 devices, providing serialized linear sensors with a graph of their precise output over a magnetic field of ± 400 gauss (A3515) or ± 800 gauss (A3516). The graph is plotted at three bias voltages 4.5 V, 5 V, and 5.5 V. Designers can use these devices to obtain extremely accurate field-

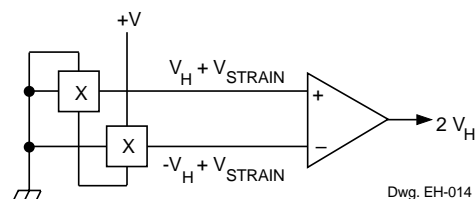

Multiple Sensors to Cancel Effects of Strain

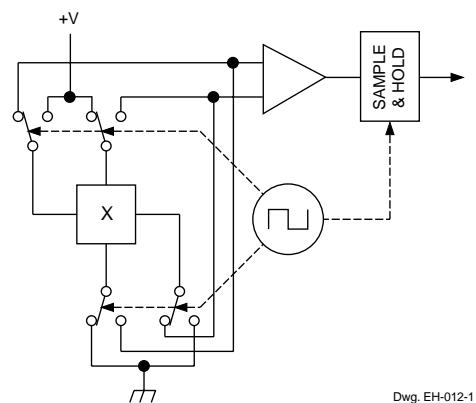

Electronically Rotated Sensor to Cancel Effects of Strain

strength measurements. Because the sensors are packaged in the popular “U” or “UA” packages, the devices are easily inserted into developmental circuits to provide an easy means of reading actual field strength. This allows precise measurements to be made of magnets and their field strengths at various air gaps. Ultimately, the calibrated linear will provide information that will greatly assist in the final selection of system magnets, air gaps, and the proper digital or linear sensor for the application.

LINEAR HALL-EFFECT SENSORS

To use, connect the appropriate terminals to a well-regulated power supply (± 0.01 V) and the output to a high-impedance voltmeter. It is also recommended that an external $0.1 \mu\text{F}$ bypass capacitor be connected (in close proximity to the Hall sensor) between the supply and ground of the device to reduce both external noise and noise generated by the chopper stabilization technique. An ambient temperature range of $+21^\circ\text{C}$ to $+25^\circ\text{C}$ should also be maintained. Before use, the device should be powered up and allowed to stabilize.

The calibrated linear sensor, with its attached calibration curve, affords a convenient method of flux measurement.

Subject the device to the magnetic field in question. Measure the device output voltage and locate that level on the Y axis of the calibration curve. The intersection of that output level with the calibration curve will provide the corresponding flux density on the calibration curve's X axis.

Alternatively, the sensitivity coefficient (as given on the calibration curve for the device) can be used to calculate flux densities more precisely. First, determine the quiescent output voltage of the device under a zero gauss or "null" field condition. Then, measure the output of the device with the unknown field applied. The magnetic flux density at the chip can then be calculated as:

$$B = 1000 (V_{OB} - V_{O0})/k$$

where B = magnetic flux density in gauss

V_{OB} = output voltage with unknown field applied

V_{O0} = output voltage with zero gauss applied

k = calibrated device sensitivity in mV/G.

CURRENT SENSING

Linear Hall-effect sensors are ideal for current sensing. Currents from the low milliamperage range into the thousands of amperes can be accurately measured.

The flow of current through a conductor will generate a free-space magnetic field of about 6.9 gauss per ampere. Because the measurement range of a linear Hall-effect sensor is limited, it is necessary to configure the sensing circuit such that the field strength of the current range to be measured is within the range of the sensor to be used. In the case of the A3516 this sensing range will be approximately -800 gauss to +800 gauss.

High-Current Measurement

For conductors with several hundred to thousands of amperes of current, the linear sensor can provide a direct usable output, without the use of field-enhancing coils or toroids, by sensing a portion of the total magnetic field generated. Lower currents will need to utilize coils or toroids to increase or concentrate the field to a detectable range. Ideally, the field will be above 100 gauss, placing the sensor output above signal-to-noise-ratio concerns. The magnetic flux density at the chip can be calculated as:

$$B \approx I/4\pi r \text{ or } I \approx 4\pi r B$$

where: B = field strength in gauss

I = current in amperes

r = distance from wire center to sensor chip in inches.

Example 1: wire has 0.25" radius, plus 0.1" air gap, 2000 amperes of current flow. $B \approx 2000/4.40 \approx 455$ G.

Example 2: wire has 0.15" radius, plus 0.1" air gap, 300 amperes of current flow. $B \approx 300/3.14 \approx 95$ G.

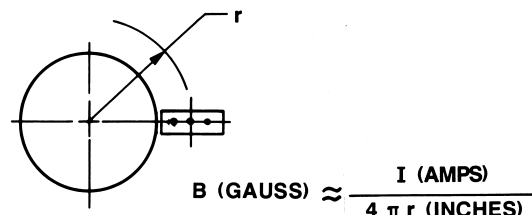

Note that the Hall element is most sensitive to magnetic fields passing perpendicularly through it. Flux lines at an angle to the device will generate reduced (cosine of the angle) Hall voltages and flux lines at 90° angles will produce a zero gauss indication.

Using A Coil for Increased Sensitivity

Flux density can be increased with the use of a coil. Using a total sensor-to-coil air gap of 0.060" yields an increase in flux density:

$$B \approx 6.9nI \text{ or } n \approx B/6.9I$$

where n = number of turns of wire in the coil.

LINEAR HALL-EFFECT SENSORS

For example, to indicate 400 gauss at 12 amperes:
 $n \approx 400/83 \approx 5$ turns.

Using A Toroid for Maximum Sensitivity

Accurate current measurements below about 120 amperes is best accomplished using a gapped toroid with the current-carrying conductor passing through the toroid and the sensor positioned in the toroid gap. The toroid will concentrate the magnetic field through the sensing element. Magnetic fields below 1 gauss are difficult to measure due to the internal noise associated with the solid-state sensor and amplifiers. The wide-band output noise of the sensor is typically 400 μ V rms (or an error of about 32 mA).

To measure low currents, the conductor should be passed through the toroid multiple times (n), resulting in

$$B \approx 6.9nI$$

where n = the number of turns.

LINEAR SENSOR APPLICATIONS USING PERMANENT MAGNETS

In many applications, the linear sensor will be used in conjunction with a permanent magnet. Several magnet configurations are shown below. To maximize linearity, a large change in field strength vs. the required displacement is desired. Careful selection of the magnet(s), and the sensing technique, will pay large dividends. In general, high-quality, high field-strength magnets are required for most linear sensing applications. Samarium-cobalt or Alnico 8 magnets are recommended.

Head-On Sensing (Single Magnet)

Though straightforward, a head-on approach produces an output that mimics the magnetic field, which produces a nonlinear output vs. air gap. At small air gaps the change in output voltage vs. air gap is large, and for some applications may be considered "linear". At larger air gaps, the output assumes a pronounced nonlinear characteristic. Linear sensors will accurately track positive or negative magnetic fields.

Features:

- sensor output tracks magnetic field and
- simple mechanical configuration.

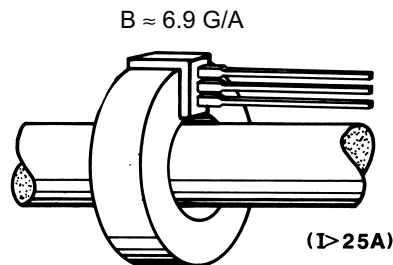

Dwg. No. 13,165

Gapped Toroid for Measuring High Currents

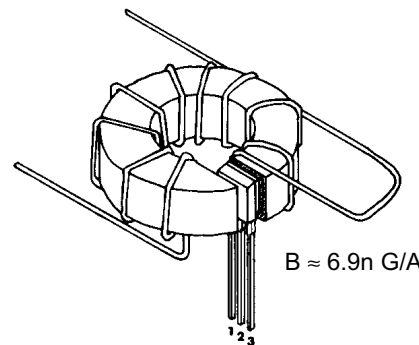

Multiple Turns for Measuring Low Currents

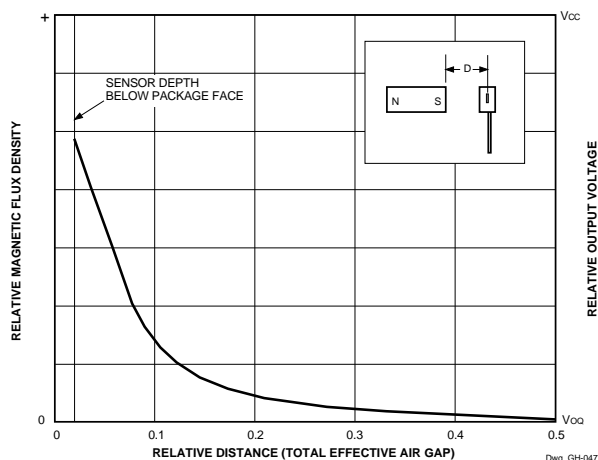

Dwg. GH-047

LINEAR HALL-EFFECT SENSORS

Slide-By Sensing (Single Magnet)

Slide-by sensing is a non-complex method of obtaining a linear output voltage vs. slide-by movement. Depending upon the location of the sensor relative to the zero-field center of the magnet, both negative and positive outputs can be produced. As the first graph shows, the center portion of the output is very linear and becomes a good choice for potentiometer, air valve, and throttle-position valve type applications.

Features:

- very linear output vs. position over a small range
- very steep magnetic (output voltage) slopes,
- very high flux density change relative to distance, and
- output is nearly rail-to-rail (ground to V_{CC}).

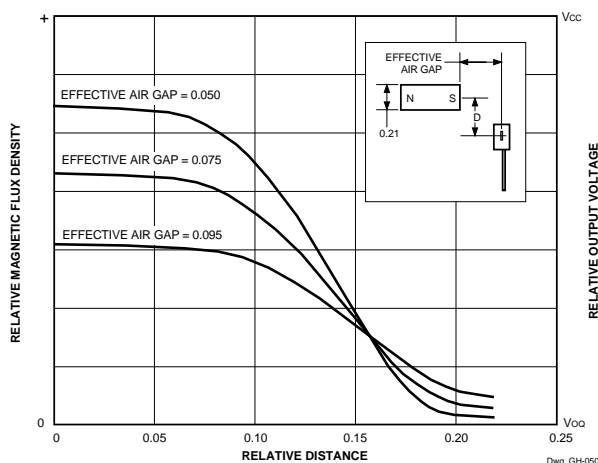
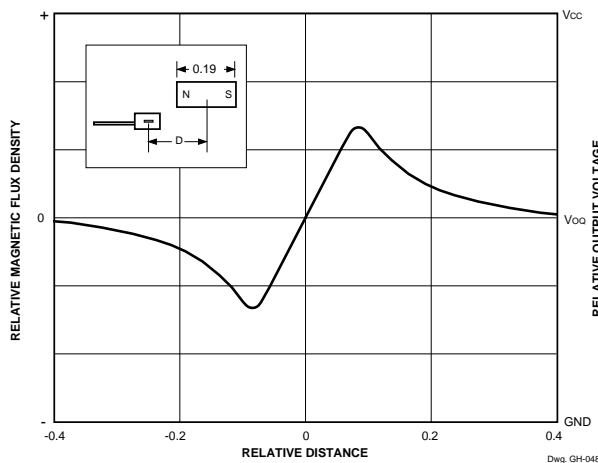

Push-Pull Approach

The sensor moves between two magnets. Complementary fields provide a linear, steep-sloped output. The output will range from zero to near plus/minus rail voltage with the polarity dependent on orientation of the magnets.

Features:

- steep magnetic (output voltage) slope,
- output is nearly rail-to-rail (ground to V_{CC}) with polarity dependent upon magnet orientation), and
- insensitive to precise positioning.

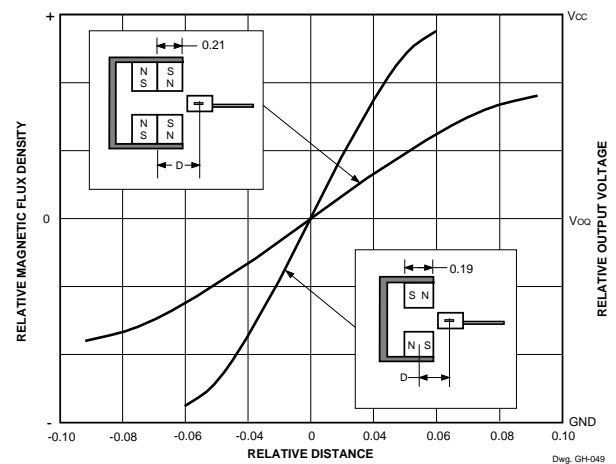

Push-Push Approach

The sensor moves between opposing magnets. The opposing fields provide a very linear, moderately steep-sloped output.

Features:

- steep magnetic (output voltage) slope,
- output is nearly rail-to-rail (ground to V_{CC}), and
- insensitive to precise positioning.

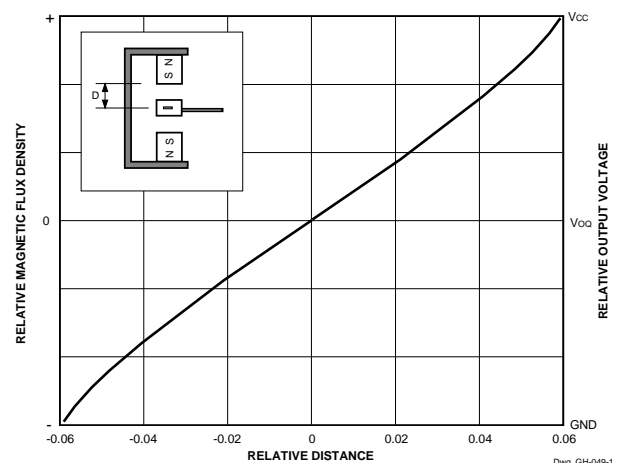

LINEAR HALL-EFFECT SENSORS

Compound Magnets

Compound magnets can be used to produce specialized outputs, including sine-wave-type outputs.

Magnetically Biased Linear Sensing

Linear sensors can be used to detect the presence or absence of a ferrous metal target. This requires bonding a biasing magnet onto the sensor*. This technology can also be used for notch or gear-tooth sensing although specialized gear-tooth sensor designs may be better suited for these applications.

OPTIMIZED LINEAR OUTPUTS

Several common circuits are used, in conjunction with linear sensors, to optimize their outputs for specialized applications.

A/D Converter Interface

Linear sensors can provide input for analog-to-digital converters. Ratiometric linear sensors can be powered from the A/D reference voltage source, allowing the sensor to track changes in the A/D LSB (least significant bit) value. As the reference voltage varies, the LSB will vary proportionally.

Look-Up Tables

When digital data is provided to a microprocessor, the sensor's output can be referenced to a lookup table, correcting for any non-linearity.

Comparators

Comparators can be utilized to provide a set point or trip point and thereby convert the linear sensor into an adjustable digital switch although chopper-stabilized Hall-effect switches may be better suited for these applications.

Operational Amplifiers

Operational amplifiers can be used to boost the output of the sensor to higher output levels and to provide adjustable offsets.

*Especially with older sensor designs, special precautions regarding soldering, gluing, potting, and encapsulating of Hall-effect devices may apply. Application note 27703.1 is available on request.

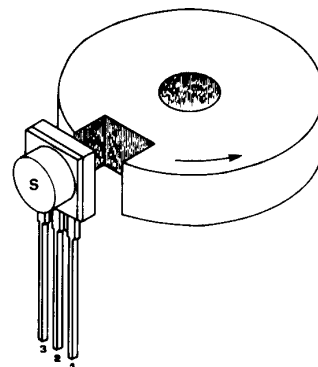
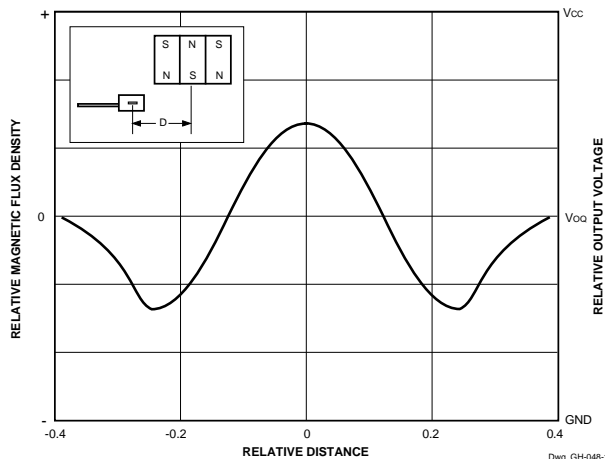

Biased Linear Sensing for Notch Detection

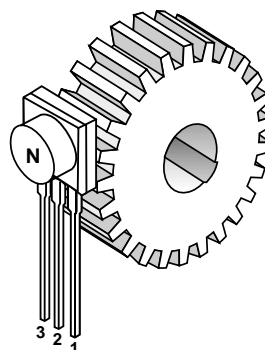

Biased Gear-Tooth Sensing

LINEAR HALL-EFFECT SENSORS

MAGNETS

Many linear-sensing applications will need high-quality magnets to optimize air gaps and provide stable fields over wide temperature ranges. The table below is a guide to basic magnet characteristics. Detailed information on particular magnet types is available from the manufacturers (see supplement).

Choosing a Magnet

A magnet must have sufficient flux density to generate the desired linear sensor output, at the working air gap required by the application. Other considerations are the temperature coefficient of the magnet and its coercive

force. Coercive force is basically the measure of a magnet's ability to retain its magnetic force when subjected to a strong demagnetizing field. The larger a magnet's coercive force, the less susceptible it is to being demagnetized.

Temperature Coefficient of Magnets

Temperature coefficient is the rate of change of the magnet's field strength over temperature, measured in gauss per degree Celsius. This is an important consideration when selecting a magnet, particularly for linear applications.

Properties of Magnetic Materials

Material	Maximum energy product (gauss-oersted)	Residual induction (gauss)	Coercive force (oersteds)	Temperature coefficient	Cost	Comments
R.E. cobalt	16×10^6	8.1×10^3	7.9×10^3	-0.05%/°C	Highest	Strongest, smallest, resists demagnetizing best
Alnico 1, 2, 3, 4	$1.3 - 1.7 \times 10^6$	$5.5 - 7.5 \times 10^3$	$0.42 - 0.72 \times 10^3$	-0.02%/°C to -0.03%/°C	Medium	Non-oriented
Alnico 5, 6, 5-7	$4.0 - 7.5 \times 10^6$	$10.5 - 13.5 \times 10^3$	$0.64 - 0.78 \times 10^3$	-0.02%/°C to -0.03%/°C	Medium-high	Oriented
Alnico 8	$5.0 - 6.0 \times 10^6$	$7 - 9.2 \times 10^3$	$1.5 - 1.9 \times 10^3$	-0.01%/°C to +0.01%/°C	Medium-high	Oriented, high coercive force, best temperature coefficient
Alnico 9	10×10^6	10.5×10^3	1.6×10^3	-0.02%/°C	High	Oriented, highest energy product
Ceramic 1	1.0×10^6	2.2×10^3	1.8×10^3	-0.2%/°C	Low	Nonoriented, high coercive force, hard, brittle, non-conductor
Ceramic 2, 3, 4, 6	$1.8 - 2.6 \times 10^6$	$2.9 - 3.3 \times 10^3$	$2.3 - 2.8 \times 10^3$	-0.2%/°C	Low-medium	Partially oriented, very high coercive force, hard, brittle, non-conductor
Ceramic 5, 7, 8	$2.8 - 3.5 \times 10^6$	$3.5 - 3.8 \times 10^3$	$2.5 - 3.3 \times 10^3$	-0.2%/°C	Medium	Fully oriented, very high coercive force, hard, brittle, non-conductor
Cunife	1.4×10^6	5.5×10^3	0.53×10^3	—	Medium	Ductile, can cold form and machine
Fe-Cr	5.25×10^6	13.5×10^3	0.60×10^3	—	Medium-	Can machine prior to final aging treatment
Plastic	$0.2 - 1.2 \times 10^3$	$1.4 - 3 \times 10^3$	$0.45 - 1.4 \times 10^3$	-0.2%/°C	Lowest	Can be molded, stamped, machined
Rubber	$0.35 - 1.1 \times 10^6$	$1.3 - 2.3 \times 10^3$	$1 - 1.8 \times 10^3$	-0.2%/°C	Lowest	Flexible
Neodymium	$7 - 15 \times 10^6$	$6.4 - 11.75 \times 10^3$	$5.3 - 6.5 \times 10^3$	-0.157%/°C to -0.192%/°C	Medium-high	Non-oriented

LINEAR HALL-EFFECT SENSORS

Magnetic Materials

Alnico is a class of alloys containing aluminum, nickel, cobalt, iron, and additives that can be varied to give a wide range of properties. These magnets are strong, and have low temperature coefficients. Alnico magnets are less expensive than rare-earth cobalt magnets but more expensive than most other materials. Alnico magnets can be cast, or sintered by pressing metal powders in a die and heat treating. Sintered Alnico is well suited to mass production of small, intricately shaped magnets. It has more uniform flux density, and is mechanically superior to most other magnetic materials. Cast Alnico magnets are generally somewhat stronger than non-oriented or isotropic Alnico alloys (1,2,3,4) and are less expensive and magnetically weaker than the oriented alloys (5,6,5-7,8,9). Alnico is too hard and brittle to be shaped except by grinding.

Ceramic magnets contain barium or strontium ferrite (or another element from that group) in a matrix of ceramic material that is compacted and sintered. Ceramics are poor conductors of heat and electricity and are chemically inert. As with Alnico, ceramic magnets can be fabricated with an oriented structure for additional magnetic strength. Ceramic magnets are less expensive than Alnico, and have a lower maximum energy product.

Cunife magnets are made from a ductile copper-base alloy with nickel and iron. They can be stamped, swagged, drawn, or rolled into final shape.

Iron-Chromium (Fe-Cr) magnets have magnetic properties similar to Alnico 5, but are soft enough to be machined before final heat treatment hardens them.

Neodymium (Ne-Fe-B) magnets compare in strength with rare-earth magnets, are less expensive, but have poor temperature coefficients. Neodymium magnets are produced by either a powdered-metal technique called “orient-press-sinter” or by casting. Oxidation problems can be overcome through the use of modern coatings.

Plastic or Rubber magnets consist of barium or strontium ferrite in a plastic or rubber matrix. These are the least expensive magnets but have the lowest maximum energy product. Plastic or rubber magnets can be formed by stamping, molding, or machining.

Rare-Earth Cobalt magnets are alloys of rare-earth metals (such as samarium) with cobalt. These magnets are the best in all categories but are also the most expensive. The material is too hard for machining and must be ground if shaping is necessary.

***LINEAR
HALL-EFFECT
SENSORS***

Allegro MicroSystems, Inc. reserves the right to make, from time to time, such departures from the detail specifications as may be required to permit improvements in the design of its products.

The information included herein is believed to be accurate and reliable. However, Allegro MicroSystems, Inc. assumes no responsibility for its use; nor for any infringements of patents or other rights of third parties which may result from its use.

LINEAR HALL-EFFECT SENSORS

SOURCES FOR FERRITE TOROIDS AND MAGNETS

As a convenience, some sources for ferrite toroids and magnets are listed below.
Addresses and telephone numbers are correct to the best of our knowledge at time of printing.

TOROID SUPPLIERS

Allstar Magnetics Inc. Vancouver, WA (360) 693-0213	Eastern Components, Inc. Schaumburg, IL (847) 310-8731 (800) 862-1640	Magnetics Butler, PA (412) 282-8282
Dexter Magnetic Materials Division Billerica, MA (508) 663-7500	Eastern Components, Inc. Norwood, MA (617) 769-9397 (800) 642-0518	J.W. Miller Co. Division of Bell Industries Rancho Dominguez, CA (213) 537-5200
Eastern Components, Inc. Chatsworth, CA (818) 727-7023 (800) 824-8596	Fair-Rite Products Corp. Wallkill, NY (914) 895-2055	Philips Components Saugerties, NY (914) 246-2811

MAGNET SUPPLIERS

Arnold Engineering Marengo, IL (815) 568-2000	Alnico, ceramic, flexible, multipole ring	The Electrodyne Company Batavia, OH (513) 732-2822	Plastic
Australian Magnet Technology Raymond Terrace, NSW, Australia (+61) 49-873988		Electron Energy Corporation Landisville, PA (717) 898-2294	
Boxmag Precision Magnets Aston, Birmingham, U.K. (+44) 121-3595061	Injection-molded rings, NeFeB	EMS-Chemie AG Domat-EMS, Switzerland (+41) 81-36-73-42	
Bunting Magnetics Company Elk Grove Village, IL (312) 593-2060	Alnico, ceramic, plastic	Euromag Sweden AB Stockholm, Sweden (+46) 8-307504	
Ceramic Magnetics, Inc. Fairfield, NJ (201) 227-4222	Ceramic, multipole ring	Flexmag Industries Cincinnati, OH (513) 554-3600	Flexible
Crucible Magnetics Elizabethtown, KY (502) 769-1333	Alnico (cast), rare earth	Gallup & Associates Rochester Hills, MI (810) 656-3131	
Daido Steel (America) Des Plaines, IL (847) 699-9066		GenCorp Evansville, IN (812) 428-6435	
Dexter Magnetic Materials Fremont, CA (510) 656-5700	Distributor for various manufacturers Also, custom grinding	General Magnetic Company Dallas, TX (214) 296-4711	
Dexter Magnetic Materials Hicksville, NY (516) 822-3311	Distributor for various manufacturers Also, custom grinding	Hitachi Magnetics, Corp. Edmore, MI (517) 427-5151	Alnico, ceramic, NeFeB, samarium
Dynacast Co. Schaumburg, IL (312) 351-6100	Plastic	Hoosier Magnetics Toledo, OH (418) 841-7173	

LINEAR HALL-EFFECT SENSORS

International Magneproducts Valparaiso, IN (219) 465-1998		Svenska Magner Fabriken AB Hallstahammar, Sweden (+46) 220-15080	
Kane Magnetics International (Formerly Stackpole Carbon Co.) Kane, PA (814) 837-7000	Ceramic, flexible plastic	Swift Levick Magnets Barlborough, Derbyshire, U.K. (+44) 1246-570500	
Magnaquench International Anderson, IN (317) 646-5000	NeFeB	Systems International Pinhole, CA (510) 724-3381	
Magnet Applications Horsham, PA (215) 441-7704	Alnico, ceramic, NeFeB, samarium	TDK Corporation of America Mount Prospect, IL (708) 390-4374	NeFeB, samarium
Magnet Sales & Mfg. Culver City, CA (310) 391-7213	Alnico, ceramic, NeFeB, samarium	Tengam Engineering Otsego, MI (616) 694-9466	Plastic barium ferrite
Magnetfabrik Schramberg Schramberg-Sulgen, Germany (+49) 7422-5190		Thyssen Magnettechnik GmbH Dortmund, Germany (+49) 231-4501-407	
National Magnetics Company Bardstown, KY (502) 348-3765		Tridus International Paramount, CA (310) 408-2222	
Neomet Corporation Edinburg, PA (412) 667-3000	NeFeB	Ugimag Valparaiso, IN (219) 462-3131	Alnico, multipole ring, NeFeB
Polymag Bellport, NY (516) 286-4111	Alnico, ceramic, flexible, sheets	Vacuumschwmeize Iselin, NJ (908) 494-3530	Alnico, NeFeB, samarium
Quadrant Technology Corp. Sunnyvale, CA (408) 261-3589	Alnico, neodymium, rare earth, ceramic	Widia Magnettechnik Essen, Germany (+49) 201-7253348	
SG Armtech Newtown, PA (215) 504-1000	Ceramic strontium ferrite	Xolox Corporation Ft. Wayne, IN (219) 432-0661	Barium ferrite, NeFeB, plastic, multipole ring
SG Magnets Rainham, Essex, U.K. (+44) 1708-558411			
Shin-Etsu Magnetics Inc. San Jose, CA (408) 383-9240	NeFeB, cerium, samarium		
Sino American Development New York, NY (212) 947-0820			
Sumitomo Special Metals Torrance, CA (310) 378-7886	NeFeB, samarium		
Sura Magnets AB Surahammer, Sweden (+46) 220-307-70			

December 3, 1998

**LINEAR
HALL-EFFECT
SENSORS**

HALL-EFFECT SENSORS SELECTION GUIDE

Partial Part Number	Avail. Oper. Temp.	Characteristics at T _A = +25°C			Features	Notes
		B _{OP} (max)	B _{RP} (min)	B _{hys} (typ)		
RATIOMETRIC, LINEAR HALL-EFFECT SENSORS						
3503	S			typ. 1.3 mV/G		
3515	E/L			typ. 5.0 mV/G	chopper stabilized	
3516	E/L			typ. 2.5 mV/G	chopper stabilized	
3517	L/S			typ. 5.0 mV/G	chopper stabilized	
3518	L/S			typ. 2.5 mV/G	chopper stabilized	
GEARTOOTH/RING MAGNET (DUAL ELEMENT) HALL-EFFECT SENSORS in order of B_{OP}						
3060	K/S	+35	-35	30	ac coupled	
3422	E/L	+75	-75	46	direction detection	
3059	K/S	+100	-100	130	ac coupled	
3056	E/L	+150	-150	50	zero-speed	
3058	E/L	+250	-250	200	zero-speed	
3421	E/L	+280	-280	335	direction detection	
SPECIAL-PURPOSE HALL-EFFECT SENSORS						
3054	K/S	+300	+5.0	50	unipolar switch, multiplexed	6
3150	J	+40 to +850	-	20	programmable, chopper stabilized	1
3210	E	±70	±5.0	7.7	micropower, chopper stabilized	
3421	E/L	+280	-280	335	direction detection	
3422	E/L	+85	-85	46	direction detection	

Operating Temperature Ranges:

S = -20°C to +85°C, E = -40°C to +85°C, J = -40°C to +115°C, K = -40°C to +125°C, L = -40°C to +150°C

Notes 1. Protected.

6. Multiplexed two-wire sensor; after proper address, power/signal bus current indicates magnetic field condition.