

DIY Kit 154. FOUR DIGIT PRESETTABLE DOWN COUNTER

INTRODUCTION

This is a low cost 4 Digit Presettable Down Counter with output and reset. The count input can be used for both high and low speed counting applications. The counter has four modes of operation that control how the output behaves when the count reaches zero.

The input, output and power supply pins are brought out to a 10-way header strip for easy connection.

A 9 to 12V DC supply is required to power the kit, which has a current consumption of 20mA to 40mA, depending on the number displayed. A 12VDC / 150mA plug pack will do fine.

TECHNICAL SPECIFICATIONS	
Supply voltage	50mA @ 12VDC
Operating modes	Count Stop, Output Hold Over-Count, Output Hold Auto-Reset, One-Shot Output Over-Count, One-Shot Output
Count range	0000 to 9999 (10,000 max)
Count speed (selectable)	Low 30 cps (15mS high, 15mS low) High 30,000 cps (measured)
Inputs	Reset, Count, Rate
Output	Transistor, NPN, 100mA @ 30V
Display	14mm RED LED
Physical size	51mm x 63mm (2.0" x 2.5")
Connection	10 pin SIL header pins, 0.1"

INPUTS AND OUTPUTS

These are organized as 'pairs' of pins, with each input or output having a corresponding ground pin. Inputs are normally pulled high and may be driven low by simple "make" contacts from switches, relays or open collector outputs.

There are three inputs:

- RESET** Resets the counter to its preset value
- RATE** Selects if debouncing is applied to the count input
- COUNT** Triggers counter on falling edge

The **RATE** input is used to enable or disable debouncing on the count input. With **RATE** high (open) debounce is enabled; with **RATE** low (closed) debounce is disabled. Enable debounce when using relay contacts or switches for input.

The debounce time is 15mS for both falling and rising edges. This means the count input must be stable for at least 15mS before it is recognized, giving a maximum counting speed of about 30 counts per second.

The open collector **OUTPUT** pin indicates when the count has reached zero. It needs an external pull-up resistor or it can be used to directly switch a relay. The **OUTPUT** is normally 'high' and either pulses 'low' or remains 'low' depending on the operating mode.

OUTPUT PULSE WIDTH (Mode C and D only)

The **OUTPUT** goes low when the count reaches 0000. It stays low until the next valid count input when it goes high again. So, the **OUTPUT** pulse width depends on the speed of the count input. So, if the count input speed is 1000cps, the pulse width will be 1mS (1/speed). If the count input speed is 10cps the pulse width will be 100mS.

OPERATING MODES

There are four operating modes that control the operation of the counter and the output pin. The RESET input does not affect the operating mode.

Mode Acount stop, output hold (default)

When the count reaches zero the output goes low and stays low. The counter stops counting. Reset to continue. This is the operating mode on power up.

Mode Bover-count, output hold

When the count reaches zero the output goes low and stays low. The count will wrap around to 9999 on the next count input and continue counting from there.

Mode Cauto-reset, one-shot output

When the count reaches zero, the counter automatically resets itself to the preset value and the output pulses low. The pulse width depends on the speed of the count input.

Mode Dover-count, one-shot output

When the count reaches zero the output pulses low. The count will wrap around to 9999 on the next count input and continue counting from there. The output pulse width depends on the speed of the count input.

PROGRAMMING THE COUNTER

Two pushbutton switches, marked "SET" and "INC", are used to preset the starting count and select the operating mode. Presetting the count value is done one digit at a time, starting with the thousands digit.

Press the SET button to enter programming mode. The display shows the current preset value of the thousands digit and the rest of the display shows minus (-) signs. Use the INC button to set the value required. Press the SET button when done.

The current preset hundreds digit is shown. Use the INC button to set the value required. Press the SET button when done.

Repeat the above steps for the tens and units digits.

After setting the units digit the display shows the current operating mode. The mode is indicated by the letters "A, b, C or d". Use the INC button to set the operating mode then press SET to exit programming mode. The display will blank momentarily to indicate that programming mode has ended.

DIY Kit 154. FOUR DIGIT PRESETTABLE DOWN COUNTER

The counter is now ready for use!

As mentioned before the RESET input resets the counter to its preset value. It does not change the operating mode. If the counter loses power it will restart in Mode A with a preset value of "0000" (count = 10,000).

CIRCUIT DESCRIPTION

The circuit used in this kit uses only one IC – the AT90S1200. It is one of the AVR family of RISC based microcontrollers from ATMEL. The pdf data sheet can be viewed (and downloaded) at "<http://www.atmel.com>"

The IC is preprogrammed. Using a microcontroller greatly reduces the component count while providing more features than could be found using dedicated logic ICs. Cost is also lower. The AT90S1200 was the choice in this kit because it has an internal RC oscillator, eliminating the need for an external crystal and loading capacitors.

The display is a single unit, common anode LED, MUX (multiplexed) display. This means that the anodes of every segment in a digit are connected together (internally) while the cathodes of like segments in each digit are tied to a common 7-segment bus line (A, B, C, etc). This minimizes the number of pins needed to drive the display but requires a more complex method to do it.

Multiplexing is a technique where each display is "active" for a short period of time. In this kit, each digit is turned ON once every 8mS for a period of 1mS. There is an OFF time of 1mS between digits.

Resistors R1-7 limit the maximum current that can flow through each segment. Transistors Q1-4 provide power to each digit.

Each input to the IC is connected via an RC network. This RC network provides some protection against high frequency noise. For the values used the time constant is approx. 20uS. Shorter duration pulses will not get through.

Transistor Q5 provides an active low, open collector overflow signal. Zener diode Z1 protects the transistor against high voltage spikes if used to drive a relay.

The circuitry is powered by IC2, a 5V regulator. Diode D1 protects against polarity reversal on its input.

IF IT DOES NOT WORK

Poor soldering ("dry joints") is the most common reason that the circuit does not work. Check all soldered joints carefully under a good light. Re-solder any that look suspicious. Check that all components are in their correct position on the PCB. Are the diodes and electrolytic capacitor the right way round?

Use a multimeter to measure the DC input voltage on the cathode of D1. It should be at least 8 volts. Anything less and the 5V regulator, IC2, will not operate correctly.

What about the transistors? Q5 is an NPN transistor while all the others are PNP types. Did you get them mixed up?

ASSEMBLY INSTRUCTIONS

Start with the lowest height components first like the resistors, diodes and IC socket. Then add the small capacitors and transistors. Next is the electrolytic capacitor. This lays flat on the PCB so the leads need to be bent over. Lastly are the pushbutton switches, right-angle header strip and display. The electrolytic capacitor, diodes and transistors need to be inserted the correct way around. These are clearly marked on the PCB overlay.

Web Address & Email

You can email me at peter@kitsrus.com

See our website at <http://kitsrus.com> for information about our Kit 122, AVR Programmer, used to program the AT89C1200-12PC, and the BASCOM Basic Compiler you can use for code development.

This kit was designed by Frank Crivelli at Ozitronics (frank@ozitronics.com).

(Document version V2.1. 10/2000, 9/2001)

PARTS LIST – K154

Resistors (0.25W carbon)

270R.....	R1-7.....	7
1K.....	R12,14,15,16,17.....	5
4K7.....	R8-11.....	4
27K.....	R13,18.....	2

Capacitors

1nF 102 ceramic.....	C1,2.....	2
100nF monobloc.....	C4.....	1
10uF 25V electrolytic.....	C3.....	1

Semiconductors

33V 1W zener diode.....	Z1.....	1
1N4004.....	D1.....	1
BC557 transistor, PNP.....	Q1-4.....	4
BC547 transistor, NPN.....	Q5.....	1
AT90S1200.....	IC1.....	1

ATMEL AVR Microcontroller, preprogrammed

78L05, 5V regulator.....	IC2.....	1
LED display, 4 digit, common anode, LN5644.....		1

Miscellaneous

Zippy pushbutton switch.....	SW1,2.....	2
20 pin IC socket.....		1
Male Header, 10 pin, right angle	X1.....	1
Female Header, 10 pin.....		1
PCB, K154.....		1

DIY Kit 154. FOUR DIGIT PRESETTABLE DOWN COUNTER

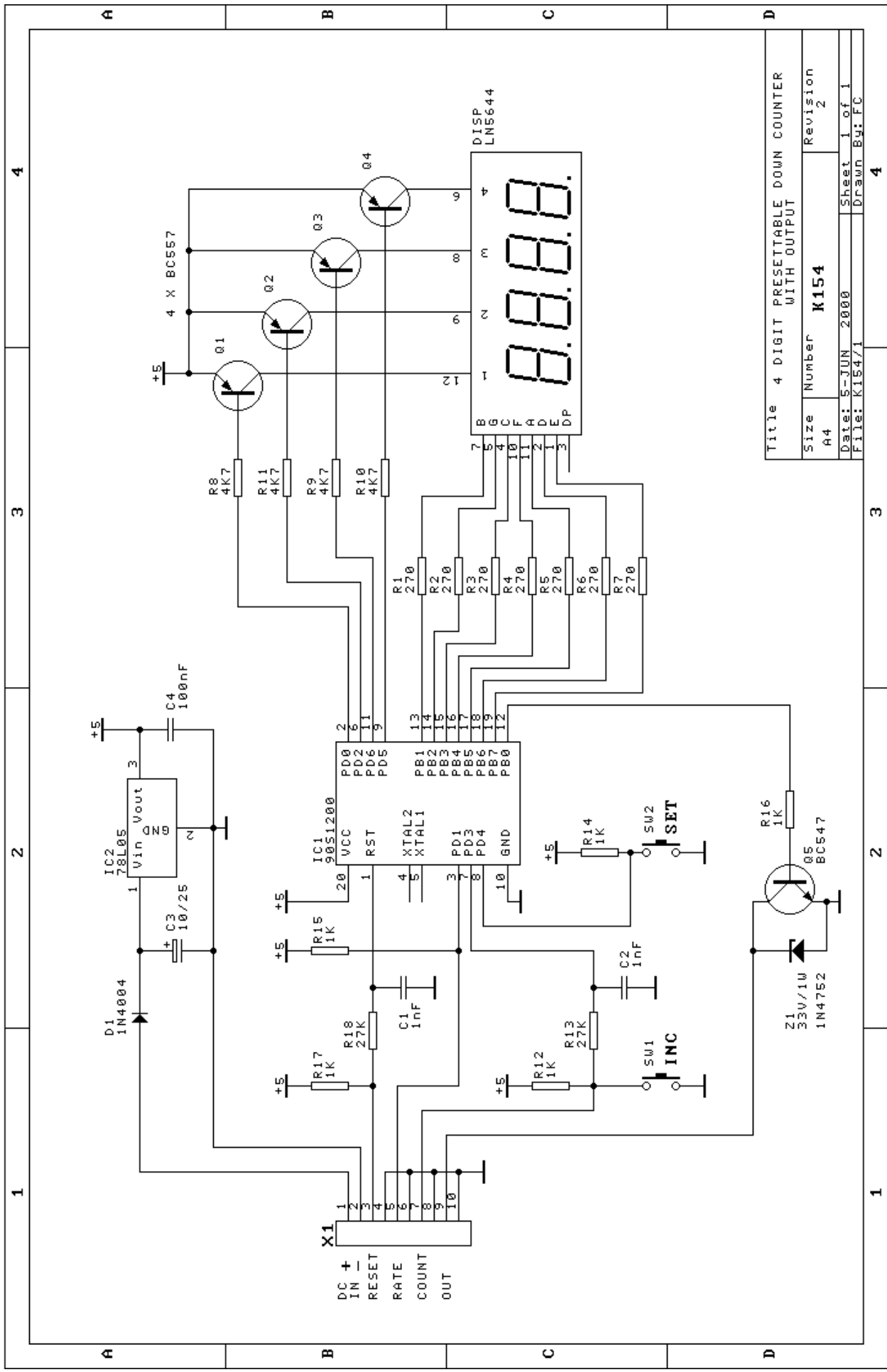

Title 4 DIGIT PRESETTABLE DOWN COUNTER WITH OUTPUT	
Size A4	Revision 2
Number K154	
Date: 5-JUN 2000	Sheet 1 of 1
File: K154/1	Drawn Bui FC