

Kit 98. Preamplifier



Our power amplifier kits have been a great success. However, unless you have a signal of sufficient amplitude they will not produce maximum power output. What is needed is a preamplifier, especially when using a microphone as input.

This preamplifier is the answer. It has a gain of up to 40 dB which is more than enough for most applications. You may vary the gain by just changing one resistor. You can also use an electret microphone by adding one resistor. We have provided this resistor and an electret microphone in the kit.

How it Works

As you can see from the circuit there are two transistors. They make up a DC feedback pair, with the negative feedback coupled from the collector of Q2 to the emitter of Q1. The input signal is applied via C3 to the base of transistor Q1. The bias voltage for this transistor is set by R1 and R4. A low pass filter consisting of R2 & C1 removes unwanted hum and noise from the DC bias voltage. This provides a degree of power supply decoupling and is usually necessary in preamp circuits to ensure that the output signal is free of hum & noise.

The output from the first stage is taken from the collector of Q1 and its 22K load resistor R3. Q1's output is fed to the base of Q2 and the final output signal is taken from its collector via C5.

Negative feedback is applied by the 2K2 resistor R5. The 1.5nF capacitor C4 across this resistor ensures stability and reduces interference from radio frequency noise by rolling off frequencies above 48kHz.

The overall gain is set by the ratio of R5 and R6. The gain equation is

$$\text{Gain} = 1 + (2200/100) = 23$$

which is approximately 27 dB. You may change R5 to adjust the overall gain if required. Keep in mind that you may need to adjust C4 as well to maintain the same high frequency roll off. For use with an electric guitar for example, you might try R5=10k and C4=470pF if there is insufficient gain with the circuit as shown. However you may prefer to leave C4 as shown to reduce noise.

The capacitor C6 in series with R6 sets the lower frequency response to 72Hz. This reduces microphone proximity effect and reduces susceptibility to wind and breath noise. If you require a flatter bass response, you may increase the value of C6. A 47 uF capacitor will give a low frequency break point of approximately 33 Hz with 6 dB per octave roll off.

Power can be supplied from any 6V to 12V DC source. At 12V the current drain is approximately 3mA. This drops to 2mA at 9V.

Optional Electret Microphone

Provision is made for an electret microphone to be used on the input. If you use this option then add resistor R9 to provide bias current for the electret microphones internal FET. If you use any other type of microphone or signal input **DO NOT include R9**.

Construction

Check the components provided against the parts list below. It is generally easier to add the lowest height components first, starting with the resistors. Make sure to get Q1 & Q2 correct, they are not the same. One is an NPN transistor while the other is a PNP type. Also make sure to get all the electrolytic capacitors around the correct way.

As mentioned above, if you are using an electret microphone then also put in the resistor R9, otherwise omit it. We have supplied both with this kit.

Testing

Connect Kit 98 to a power amplifier and speaker to try it out. Make sure you reduce the volume level first. Connect the microphone or signal source. If there is no output, then recheck all wiring, the component positions, and their orientation. Also check for bad solder joints. It is best to use shielded audio cable for the input signal and the connections between Kit 98 and power amp.

Specification

DC Input :	6 – 12 V at 2 – 3 mA
Maximum output :	~ 2.5 V RMS with 12 V supply
Maximum input :	~ 100 mV RMS (gain = 27 dB)
Frequency resp. :	~ 70 Hz to 45 kHz –3 dB (circuit as shown)
THD at 1V 1kHz :	< 0.1 %
S/N ratio :	> 75 dBA

Kit 98. Preamplifier

<http://kitsrus.com>

References

This kit is adapted from *Silicon Chip*, July 1994.

See our website for our full range of kits :

Circuit Diagram

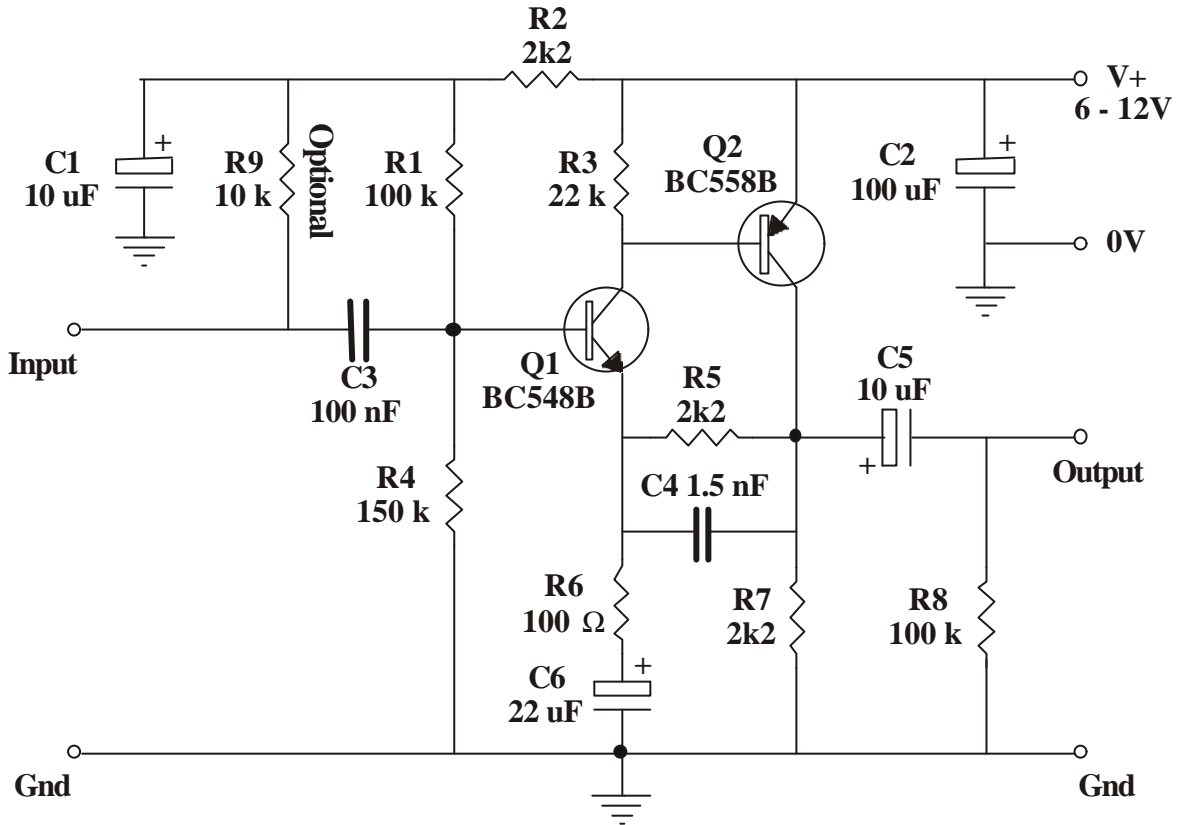

Kit 98. Preamplifier

PARTS LIST

Resistors 5%, carbon:

100R.....	R6	1
2K2	R2 R5 R7	3
10K	R9	1
22K	R3	1
100K	R1 R8.....	2
150K	R4	1

Capacitors

100nF box poly	C3	1
1.5nF box poly	C4	1
10uF mini ecap.....	C1 C5	2
22uF mini ecap	C6	1
100uF/16V mini ecap	C2	1

BC548B.....	Q1	1
BC558B.....	Q2.....	1
Kit 98 PCB		1
Electret microphone		1

