

Kit 105. 18 Watt Audio Amplifier



Kit 105 is a class AB audio power amplifier using the Hitachi HA13118 module. It is easy to construct and has a minimum of external components. The module has a high power output from a low voltage supply using the bridge tied load method, and a high gain of 55dB. This will be especially useful in applications where the input signal is a low level, without requiring the use of a separate pre-amplifier, eg. a guitar practice amplifier.

Full current, and thermal protection is provided by the IC, making it extremely reliable.

Specifications :

D.C. Input :	8 – 18V at 1 - 2 A
Power output :	18W maximum, 4 ohm load, 18V DC supply > 10W RMS 4 ohm load, 18V DC supply > 5W RMS 8 ohm load 18V DC supply > 6W RMS 4 ohm load 12V DC supply
S/N ratio :	> 70 dB
THD	< 0.2% @ 1W
Freq. Response :	~ 30 Hz to 30 kHz, -3 dB
Input level :	< 25 mV, for full output (G > 50dB)
Input Impedance	~ 30 k ohm

The supply voltage required for this kit is 8 - 18V DC, at least 1 to 2 Amps. Maximum output power will only be obtained with a power supply of 18V at greater than 2 A, using a 4 ohm speaker. The power supply should be well filtered to reduce mains hum, a regulated supply will reduce noise even further. Extra filtering is unnecessary if operating from a battery supply.

Construction.

Follow the printed circuit overlay with reference to the circuit diagram where necessary. Add the lowest height components

to the board first, starting with the resistors. Be careful to get the electrolytic capacitors in the correct way around and all parts in their correct positions. Be careful when soldering the IC not to use excessive heat. Use some heat sink compound between the heat sink & the IC if possible. Use shielded signal wire for the input connections, and at least 16/0.2 hook up wire for DC input and speaker outputs. Try to keep lead lengths as short as possible

Operation.

The circuit is very straight forward. Most of the circuitry is contained within the amplifier module. C10 is the input coupling capacitor and blocks DC from the input. C11 bypasses any RF which may be present at the input. C1 & C2 provide an AC ground for the inverting inputs of the IC. R1/C7 and R2/C8 provide a high frequency load for stability with difficult speakers. C5 and C6 provide “bootstrap” feedback for the IC. C9 and C12 provide power supply filtering.

There is no input attenuation provided, so if you require a volume control, then you should use an externally mounted logarithmic potentiometer of between 10k ohm and 50k ohm, as shown in the circuit diagram, depending on the desired input impedance. You should keep the impedance as high as possible for a guitar amp, unless using a separate pre-amp.

The absolute maximum supply voltage for this Kit is 26V, however operation above 18V is not recommended. Check the power supply voltage and polarity before connecting to the board. You should have no trouble in getting this kit to work. If yours does not work, first check all external wiring, make sure there are no shorts, then check all the component positions and orientation. Also check all solder joints and make sure there are no solder bridges.

You may download the full data sheet for the HA13118 IC from our website at :

[http:// kitsrus.com](http://kitsrus.com)

Kit 105. 18 Watt Audio Amplifier

Circuit Diagram

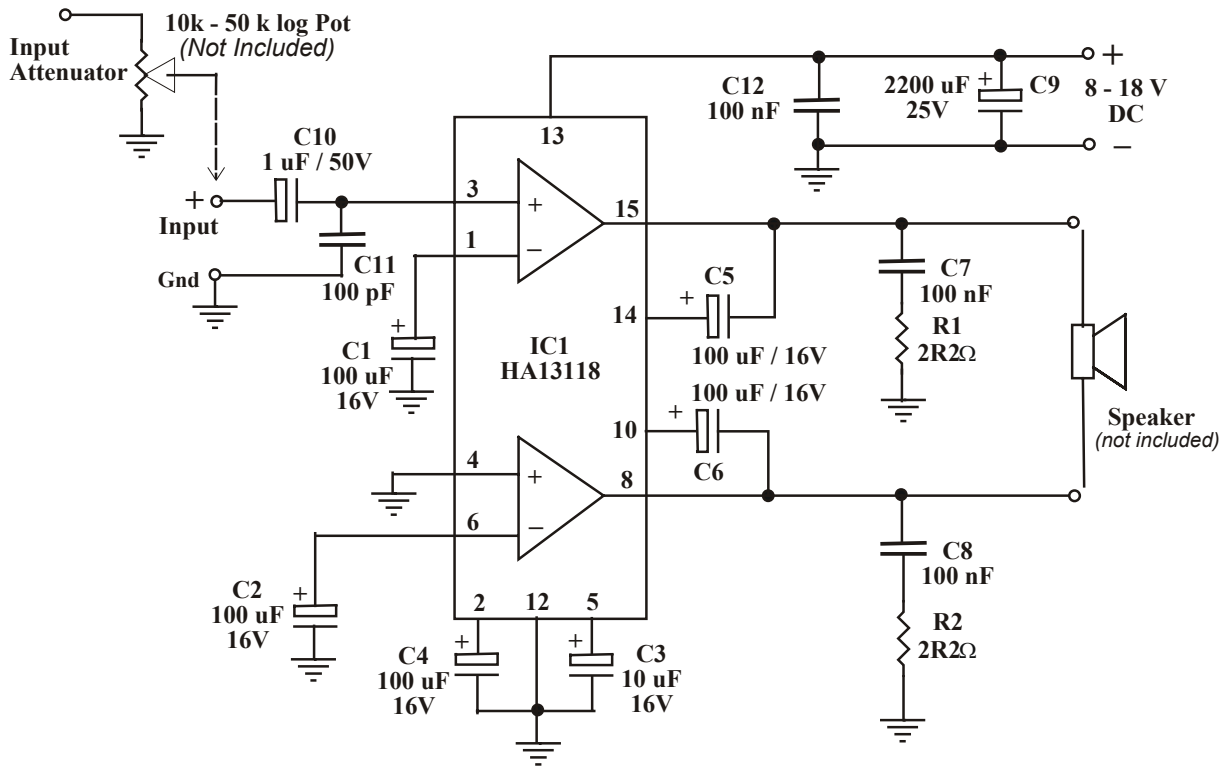

* Warning. Do not ground either speaker output.

Components

Resistors : 1/2W, 5%.

R1, R2 2R2 ohm (red red gold)

Qty.

2

Capacitors :

C1, C2, C4, C5, C6 100 uF 16V ecap

C3 10 uF 16V ecap

C7, C8, C12 100 nF box poly

C9 2,200 uF 25V ecap

C10 1 uF 50V ecap

C11 100 pF

5

1

3

1

1

1

Misc.

HA13118 amplifier I.C.

Heat sink HS215

Nut & bolt set for HS

K105 Printed Circuit Board

1

1

1

1

Kit 105. 18 Watt Audio Amplifier

**Distortion @ 1W RMS Output
1 kHz input and 12V DC supply.**

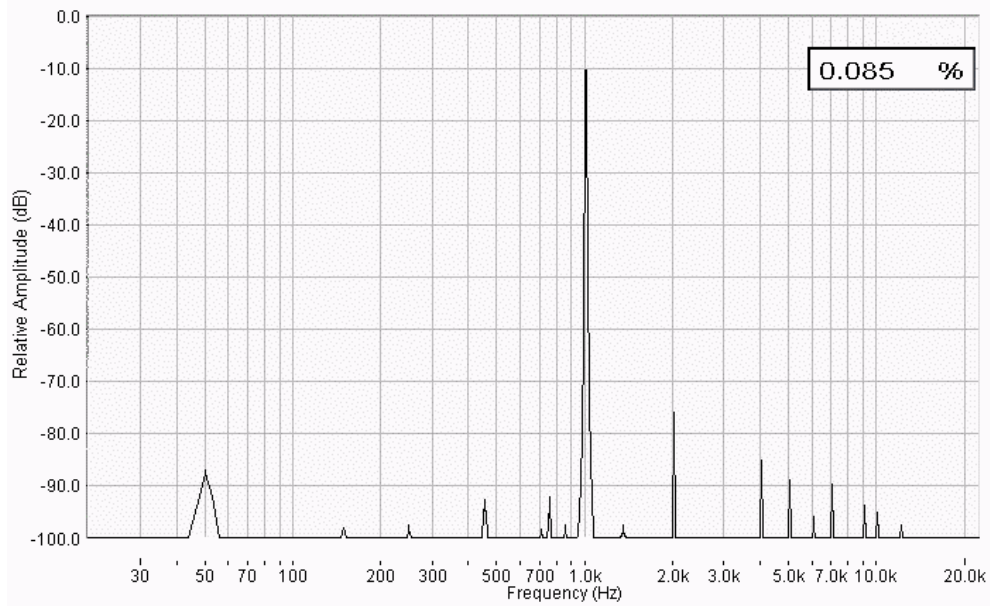

Photo of completed Kit.

